



 www.kukirin.net

 service@kukirin.net

KUKirin G2 Max

OPERATION MANUAL



www.kukirin.net

English

Contents

1.Warning	2.Caution	3.Sketch map
4.Argument list	5.Packing list	6.Assembly guidelines
7.Maintenance	8.Operation instruction	9.Troubleshooting
10.Battery charging	11.Warranty	

1.Warning

It is important to have a thorough understanding of your new electric scooter so that you can achieve the best performance, comfort, fun, and safety while cycling. To understand the new scooter and its correct operation, you should first carefully read the manual.

It is important to ride for the first time in a safe and controlled manner. For example, stay away from cars, obstacles, and other riders. It should be prohibited to enter highways, motor vehicle lanes, public lanes, reverse traffic, and avoid cycling in the rain. When encountering waterlogged roads, you should slow down and detour.

Scooters are vehicles with certain risks. Do not use mobile phones or wear headphones while cycling. It is necessary to understand the traffic rules for riding electric scooters on local public roads. When you ride every time, you should follow the rules. For your own safety, don't forget to wear a qualified helmet before getting on the scooter. It is recommended to use protective equipment such as elbow and knee pads to provide better protection.

When electric scooters are supplied, there is no basic mandatory equipment, and the situation may vary in different regions. Therefore, if you plan to use electric scooters on public roads, it is necessary to equip electric scooters with basic mandatory equipment in accordance with relevant laws and regulations.

This product is designed specifically for your personal use. Do not use it for commercial or other purposes.

Please keep this manual properly for reference.

2.Caution

Before cycling, the tire pressure should be checked, the handlebars should be installed correctly and securely. Please ensure that the battery is fully charged. If the battery is low during cycling, please keep the vehicle moving slowly and steadily. Charging should be done as soon as possible.

Before each charging, please check the charger, cables, and plugs. If there is any damage, do not use a charger.

When braking on slippery roads, the braking distance is usually longer than on dry roads. Therefore, it is necessary to brake earlier to park more safely.

You should try to avoid using electric scooters on rainy, stormy, or snowy days. If electrical components (control units, engines, and batteries) become damp or submerged, irreversible damage can occur, even leading to battery explosion.

This product can only be used by one adult at a time. Do not carry any additional passengers. If you feel uncomfortable or under the influence of alcohol or drugs, please do not ride a scooter.

The vehicle is not a toy. Like other vehicles, there is a possibility of falling, colliding, or encountering other dangerous situations. Please do not provide your electric scooter to anyone who does not know how to use it correctly. If you allow others to ride your scooter, it is your responsibility to ensure that all riders are aware of all warnings, precautions, instructions, and safety precautions, and to ensure that they are able to use this product safely and responsibly, and to protect themselves and others from harm.

Electric scooters should be kept away from flammable materials and open flames.

3.Sketch map

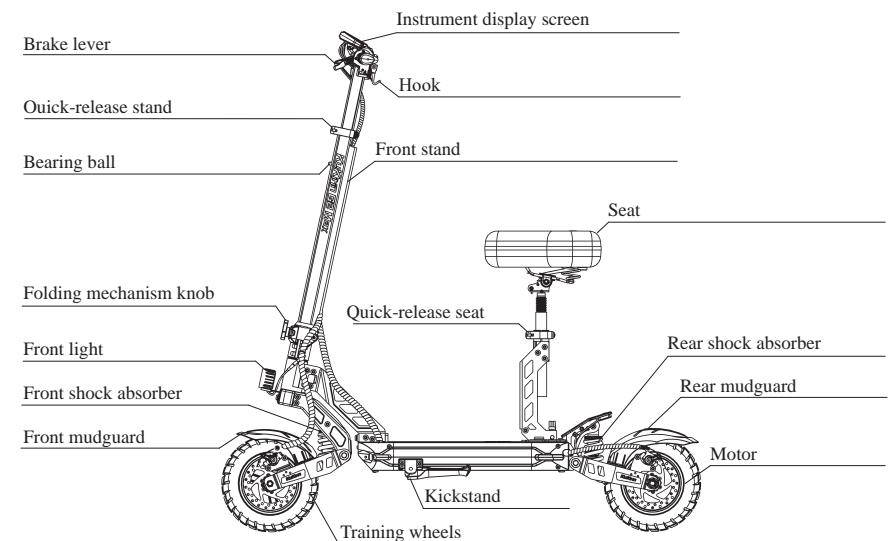

4. Argument list

Product name	KUKiTiN G2 Max	
Size	Folded size	1260*605*580 mm
	Unfolded size	1260*605*1300 mm
Parameters	Maximum speed	≤ 25 km/h
	Medium-speed endurance	≤ 70 km
	Maximum slope	≤ 22°
	Tires	10 inch off-road tires
	Shock-absorbing	Spring suspension
	Waterproof	IP54
	Brakes	Front and rear disc brakes
	Display device	Speed, mileage, battery level, front light, etc.
	Lighting	LED
Battery data	Input voltage	100~240V/50~60Hz
	Voltage/Capacity	48V/20.8Ah
	Charging time	54.6V/2A chargers, charging takes about 10 hours.
Maximum load	Maximum load	120 kg
Weight	Net weight	About 31 kg

5. Packing list



1. User's manual*1



2. Tire pump*1

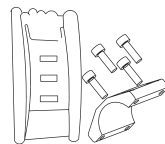

3. Tool kit and screw accessories

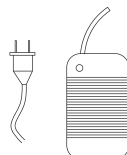

4. Charger*1

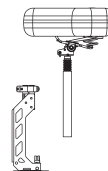

5. Seat and seat frame

Please carefully check for any loss or damage. If so, please contact us promptly.

6. Assembly guidelines

Unpacking and assembly

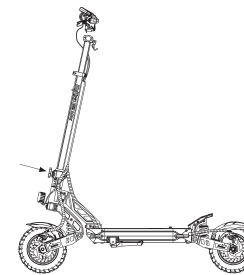

1. Turn the knob to secure the folding switch.

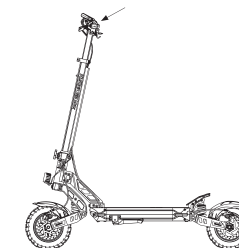

2. Put the handle tube into the fixed seat.

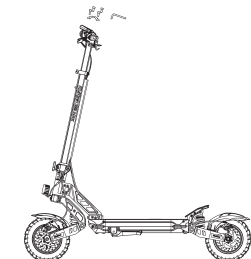

3. Tighten the screws and check the power switch.

Fold and unfold

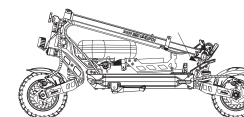

1. Drop the hook and pull the standing bar.

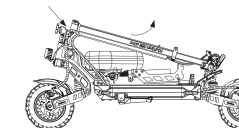

2. Pull up the upright pole.

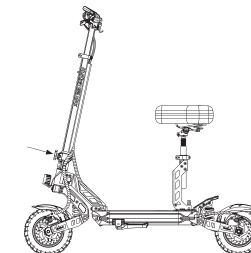

3. Turn the knob to lock the folding clip.

7. Maintenance

Lubricating oil: Every six months, a small amount of white lubricating grease or lubricant needs to be added to the folded area for maintenance. The scooter should be inspected every three months to see if any screws are loose. If any are loose, please tighten them.

Battery: When the scooter is charging or not in use, please turn off the power. When it is not in use for a long time, the electric scooter should be placed in a safe location and charged at least once every 3 months.

Storage: Please do not leave the scooter in scorching sun or other severely humid areas for a long time. Please keep the scooter clean.

8.Operation instruction

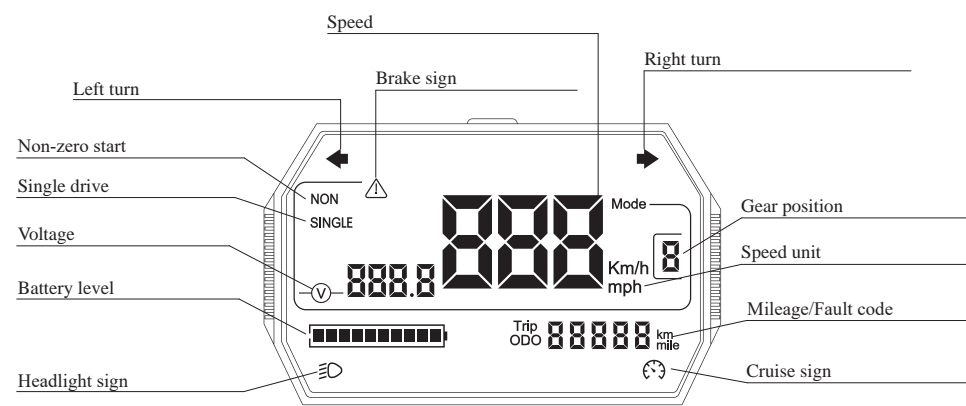
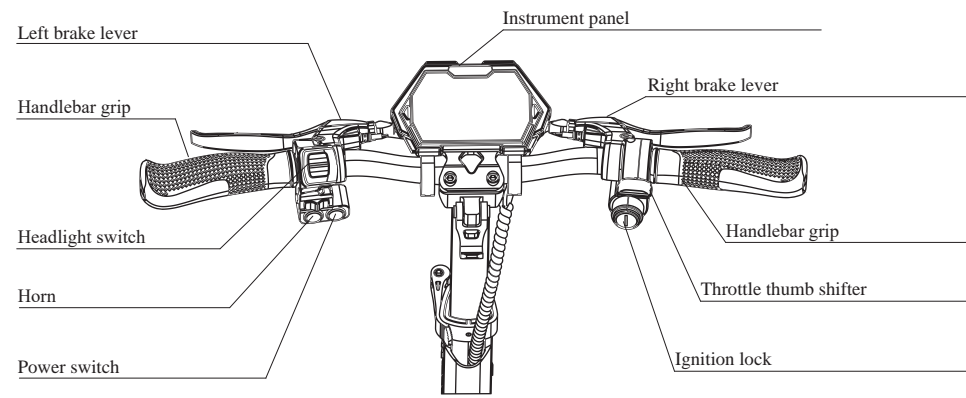

- 1.Long press the power button to turn it on/off.
- 2.Short press the power button once to switch gears. There are three levels.
- 3.Press the power button three times in a row to enter the menu setting interface. The instrument panel will display P01, P02, P03, P04, P05, P06, P07, P08, PA, PB.
- P01: Kilometer/mile selection settings, (default is kilometers).
- P02: Voltage level setting, 36V/48V/52V/60V/72V (default value is 48V).
- P03: The unit of wheel diameter is inch, which can be set to 080-160 (default is 100).
- P04: Speed measurement magnetic pole range: 1-100, (default is 30).
- P05: Cruise selection, 0 is no cruise, 1 is cruise, (default is no cruise).
- P06: Zero start/non zero start settings, 0 is zero start, 1 is non zero start, (default is zero start).
- P07: Speed limit setting: range 0-100 percentage speed limit; (default 100).
- P08: For the setting of sleep time, 0 is not sleep, and other numbers are sleep time, (default is 5 minutes).
- PA: Starting force setting, 1-5, 1 minimum, 5 maximum.
- PB: For the braking force setting, it is from 0-5, 0 is turned off, and the braking force of 1-5 gradually increases.

9.Troubleshooting

Malfunction	Code	Solutions
Rear motor malfunction	E001	Retry after replacing the rear motor/controller.
Throttle malfunction	E002	Retry after replacing the throttle.
Controller malfunction	E003	Retry after replacing the controller.
Under-voltage	E005	Low battery level, recharge and retry.
Instrument malfunction	E006	Retry after replacing the instrument/controller.
Instrument malfunction	E007	Retry after replacing the instrument/controller.

10.Charging

Friendly reminder: When charging, the charger indicator light is red; it turns green when fully charged.

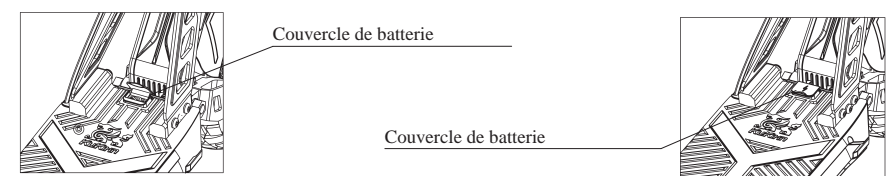

11.Warranty

From the date of receipt to the warranty period, if this product occurs malfunctions or is damaged,it can be repaired, exchanged, or returned for free after being tested and confirmed by the KuKirin after-sales center. When applying, please contact the product seller and follow the instructions. At that time, you need to provide accurate, complete, and valid purchase information or invoices.

Warranty content	Warranty period
Controller, instrument, motor, lithium battery, charger.	Half a year
Frame, front body, rear wheel hub, brakes, folding, body lever, front fork, brake system, throttle dial, etc.	1 year