

Sofirn IF19 Manual

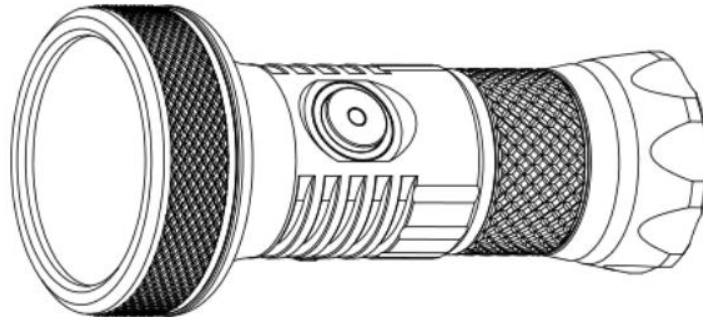

Thank you for purchasing this sofirn product.

Contact

us@sofirnlight.com

sofirnlight@gmail.com

if you need assistance.

Sofirn IF19 carries forth the classic design of IF22A. It is a little bit smaller and lighter. Speaking of modes, the IF19 ranges from the low-end 1 lumens up to a blindingly bright 2000 lumens. At that 2000-lumen turbo mode, you can easily see objects at 461m. It runs on a 18350 rechargeable battery. It has good runtime and, at the max brightness, you can run it continuously for 45 minutes. With a tight hot spot and narrow illumination angle, this thrower in some ways outshines other thrower flashlight on the market. The user interface is great, providing easy access to toggle between modes.

ANSI/NEMA FL1 Chart

Mode	Low	Med	High	Turbo	Moon
Luminous Flux	80lm	500lm	1000lm	2000lm	1lm
Runtime	5h 30min	1h 40min	1h 10min	45min	200h
Beam Distance	93m	255m	320m	461m	15m
Peak Intensity	2179cd	12692cd	25642cd	54250cd	55cd
Impact Resistance	1m / 3.28 ft.				
Water Resistance	IP68				
Charging Specification	Type-C port, input/output DC 5V/ 1A(max)				
Notes	The above mentioned parameters are based on tests according to international flashlight testing standards (ANSI/NEMA FL1) using one 1100mAh 18350 Li-ion battery in our laboratory. Results may vary with different battery or under different environmental conditions. Operation temperature is 0°C - 40°C.				

Specifications

- ❖ Emitter: 1x LUMINUS SST-40 LED with a lifespan of 50,000 hours
- ❖ Operating voltage: 2.8V—4.2V
- ❖ Battery options: 1x 18350 rechargeable lithium-ion batter
- ❖ Dimension: 85.1mm (length) × 40mm (head diameter)
- ❖ Weight: 75 grams (without battery)
- ❖ Flashlight body: Aerospace grade 6061 grade aluminum alloy, CNC manufactured to hard-anodized to military grade specification type III, anti-abrasive finish to get solid built body, anti-crash geometry and better heat exchange.
- ❖ 3° TIR lens
- ❖ Water resistance: IP68 (up to 2 meter under water, not for diving)
- ❖ Mode Memory: the flashlight memorizes the last brightness level used in the general modes (Low/Med/High)
- ❖ Reverse polarity protection from improper battery installation
- ❖ Low battery level warning: When the battery voltage is lower than 3.0V, the LED indicator in the side switch will flash red. Please recharge the battery.
- ❖ Low voltage protection: The flashlight steps down automatically when the voltage is lower than 3.0V. It also turns off automatically if the voltage gets too low. Please recharge the battery.
- ❖ Advanced Temperature Regulation (ATR) technology: As the temperature rises(above 55°C), IF19 is programmed to automatically step down the brightness to prevent over-heating.

Battery Specifications

Battery Type	Dimension & Quantity	Compatibility
Rechargeable li-ion battery	18350x 1	Yes, recommended

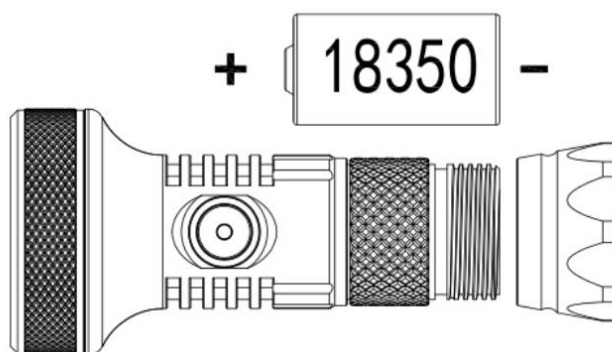

Battery Installation

Before first use, please unscrew the tailcap and remove the insulating film. If the battery needs to be replaced, make sure that the positive end of the battery faces the flashlight head when you put it in.

Power Indicator

The LED indicator in the side switch shows the power status for 5 seconds after turning IF19 on.

Green = remaining battery power is good.

Red = remaining battery power is poor.

Flashing Red = critical power, please replace or recharge battery as soon as possible.

Charging

IF19 offers a USB type-C charging port for convenient charging. Please connect it with the included USB-A to USB-C cable and use a USB power adapter (not included) with 5V/1A (max) output. It takes approximately 2.5 hours to fully charge one 1100mAh 18350 battery.

Operation Instructions

STEPPED RAMPING

ON/OFF: Single click the switch to turn the light

CHANGE BRIGHTNESS LEVEL: When the flashlight is on, press and hold the switch and it will, starting from the remembered brightness level, automatically cycle through Low, Medium, and High. The mode is selected when the switch has been released. (Please note: Moon, Turbo and Strobe are not in the automatic cycle).

TURBO AND RETURN: In any setting, double click on the switch to enter into Turbo, single click again to return.

STROBE AND RETURN: when the flashlight is on non-lockout mode, triple click on the switch to enter into Strobe, single click again to return.

LOCK/UNLOCK: When the flashlight is off, 4 fast clicks to lock the flashlight. LED blinks twice to signal that the light is in lock mode. Fast two, three or four clicks on the switch to unlock it returning to previously used mode. You can only use moonlight by holding the switch while being locked. LED will flash twice to indicate the flashlight is in lock mode when you try other operations.

MOONLIGHT MODE: When the flashlight is off, hold the switch to enter into Moonlight. Then one click to turn off or hold the switch again to enter Low cycling through the general brightness settings.

SWITCH BETWEEN DIFFERENT GROUPS

While the flashlight is on, fast four clicks to switch between group 1 and group 2. LED blinks twice to signal that the group switch is completed.

SMOOTH RAMPING

ON/OFF: Single click the switch to turn the light

RAMPING UP/DOWN: Hold and press the switch to change brightness steplessly. Ramping changes its direction when the switch is being pressed again within 1.5 seconds. The LED flashes once when it reaches the lower or upper end of the ramp.

Other operations are the same as GROUP 1.

STANDBY LOCK/UNLOCK: When the flashlight turns off after 1 minute, it will automatically enter lockout mode. Fast two, three or four clicks on the switch to unlock it returning to previously used mode. You can only use moonlight by holding the switch while being locked. LED will flash twice to indicate the flashlight is in lock mode when you try other operations.

Safety Instructions

- ❖ IF19 is a powerful flashlight. Never point it directly at a person, animal or moving vehicles. Doing so could cause retinal damage. Please do not allow children to play with it. Strobe mode may cause seizure in persons with photosensitive epilepsy.
- ❖ Operating IF19 for a long time in high powered modes will quickly heat up the flashlight. This is normal.
- ❖ Pay close attention to the proper installation of the battery. Always check that the positive end of the battery is visible when you unscrew the head from the tube before screwing the tube back on.
- ❖ Please unscrew the head half a turn to avoid unwanted activation during transport. It also prevents the battery from draining while the flashlight is in standby.
- ❖ Avoid hitting or dropping the flashlight.
- ❖

Troubleshooting and Maintenance

- ❖ Disassembling the sealed head can damage the flashlight and voids the warranty.
- ❖ Sofirn, Ltd. recommends using high-quality brand batteries. Damage by battery leakage voids the warranty.
- ❖ Remove the battery if the flashlight will not be used for an extended period of time.
- ❖ To prevent self-discharge or accidental activation during storage or transportation, unscrew the head from the tube by half a turn or remove the battery.
- ❖ Every 6 months threads should be wiped with a clean cloth followed by a thin layer of silicone grease.
- ❖ To maintain a proper level of waterproofness, replace worn-out o-rings with an approved spare.
- ❖ Troubleshooting: Clean battery contacts regularly as dirty contacts may impair the performance of the flashlight. If you experience problems (flicker, shine intermittently or failure turn on) the following root causes and solutions should be tried:

Reason A: The battery needs a replacement (battery voltage is below 2.7V).

Solution: Replace the battery with an approved type of a fully charged battery.

Reason B: Threads, PCB board contact or other contacts are dirty.

Solutions: Please clean the contact points with a cotton swab soaked in rubbing alcohol.

Reason C: The flashlight will not turn on upon first use.

Solution: Please do not forget to remove the insulation sticker from the battery on first use.

If the above methods do not work please refer to the warranty policy before contacting your authorized distributor.

Sofirn Limited:

Tel: +86-755-23440047 Fax: +86-755-23440141

Web: www.sofirnlight.com

E-mail: us@sofirnlight.com eu@sofirnlight.com

Please contact us if you have any questions.

If your product is defective please contact us for replacement within warranty period.

Manufacturer: Shenzhenshi Jinba Technology Co.,Ltd

Address: 1/F to 9/F, 1st Building, NO.110 Tenglong Industrial Center, Guanlan Street, Longhua New District, Shenzhen 518000, China