



 www.kukirin.net

 service@kukirin.net

KUKirin G3

OPERATION MANUAL



www.kukirin.net

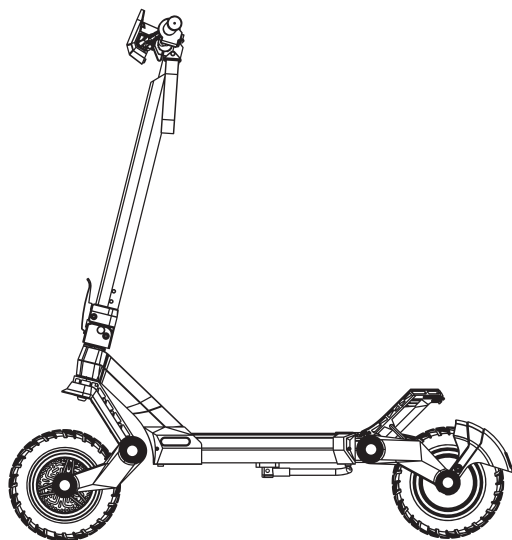

The images in this manual are for reference only. Please refer to the actual product for details.

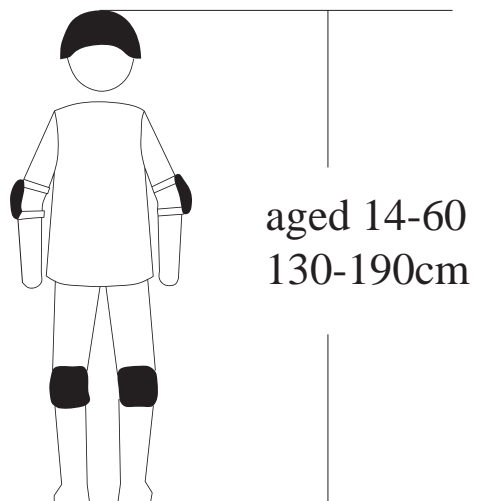

! When riding a scooter, please wear a helmet, knee pads, elbow pads, wrist guards, and other protective gear throughout the journey to reduce the risk of injury.

English

Contents

1.Warning	2.Caution	3.Sketch map
4.Argument list	5.Packing list	6.Assembly guidelines
7.Tips for beginners	8.Operation instruction	9.Troubleshooting
10.Battery charging	11.Maintenance	12.Warranty
13.Warranty Card		

1.Warning

- !** It is important to have a thorough understanding of your new electric scooter so that you can achieve the best performance, comfort, fun, and safety while cycling. To understand the new scooter and its correct operation, you should first carefully read the manual.
- !** It is important to ride for the first time in a safe and controlled manner. For example, stay away from cars, obstacles, and other riders. It should be prohibited to enter highways, motor vehicle lanes, public lanes, reverse traffic, and avoid cycling in the rain. When encountering waterlogged roads, you should slow down and detour.
- !** Scooters are vehicles with certain risks. Do not use mobile phones or wear headphones while cycling. It is necessary to understand the traffic rules for riding electric scooters on local public roads. When you ride every time, you should follow the rules. For your own safety, don't forget to wear a qualified helmet before getting on the scooter. It is recommended to use protective equipment such as elbow and knee pads to provide better protection.
- !** When electric scooters are supplied, there is no basic mandatory equipment, and the situation may vary in different regions. Therefore, if you plan to use electric scooters on public roads, it is necessary to equip electric scooters with basic mandatory equipment in accordance with relevant laws and regulations.
- !** This product is designed specifically for your personal use. Do not use it for commercial or other purposes. Please keep this manual properly for reference.

2. Caution

Before cycling, the tire pressure should be checked, the handlebars should be installed correctly and securely. Please ensure that the battery is fully charged. If the battery is low during cycling, please keep the vehicle moving slowly and steadily. Charging should be done as soon as possible.

Before each charging, please check the charger, cables, and plugs. If there is any damage, do not use a charger.

When braking on slippery roads, the braking distance is usually longer than on dry roads. Therefore, it is necessary to brake earlier to park more safely.

You should try to avoid using electric scooters on rainy, stormy, or snowy days. If electrical components (control units, engines, and batteries) become damp or submerged, irreversible damage can occur, even leading to battery explosion.

This product can only be used by one adult at a time. Do not carry any additional passengers. If you feel uncomfortable or under the influence of alcohol or drugs, please do not ride a scooter.

The vehicle is not a toy. Like other vehicles, there is a possibility of falling, colliding, or encountering other dangerous situations. Please do not provide your electric scooter to anyone who does not know how to use it correctly. If you allow others to ride your scooter, it is your responsibility to ensure that all riders are aware of all warnings, precautions, instructions, and safety precautions, and to ensure that they are able to use this product safely and responsibly, and to protect themselves and others from harm.

Electric scooters should be kept away from flammable materials and open flames.

3. Sketch map

Note: The noise of the vehicle is less than 70 dB.

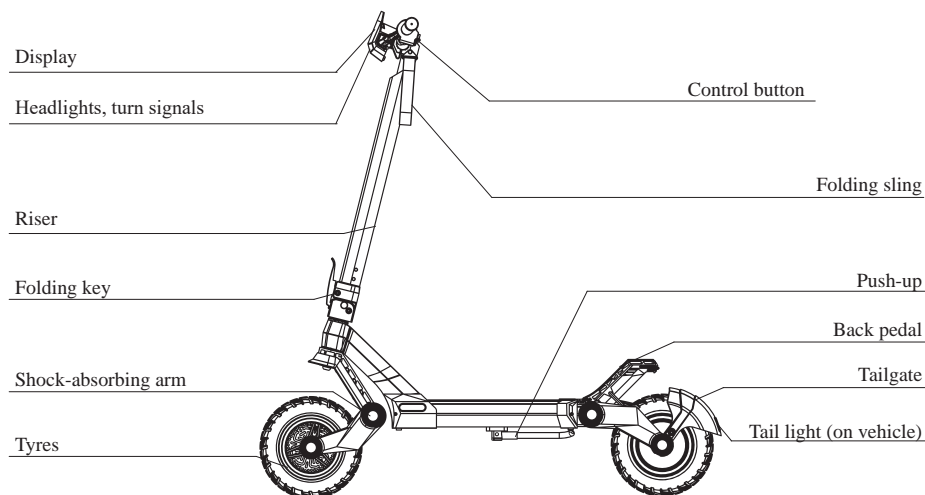

4. Argument list

Product name	KUKirin G3	
Size	Folded size	1200*660*550mm
	Unfolded size	1200*660*1290mm
Parameters	Maximum speed	≤ 25 km/h
	Medium-speed endurance	≤ 63 km
	Maximum slope	≤ 23°
	Tires	10-inch vacuum tyres
	Shock-absorbing	Spring suspension
	Waterproof	IP54
	Brakes	Front and rear disc brakes
	Display device	Speed, mileage, battery level, front light, etc.
Battery data	Input voltage	100~240V/50~60Hz
	Voltage/Capacity	52V/18Ah
	Charging time	58.8V/2A chargers, charging takes about 10 hours.
Maximum load	Maximum load	120 kg
Weight	Net weight	About 25 kg

5. Packing list



1. Instruction manual *1

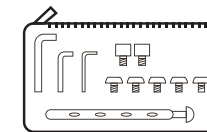

2. Tool kit and screw accessories

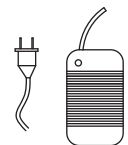

3. Charger*1

! Please carefully check for any loss or damage. If so, please contact us promptly.

6. Assembly guidelines

Unpacking and assembly

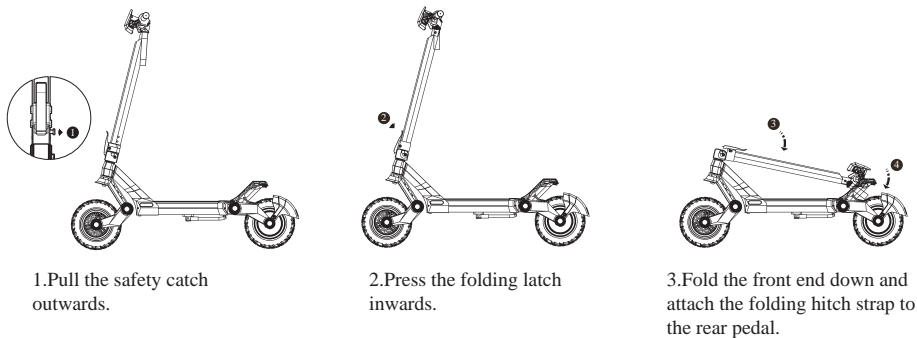

Fold and unfold

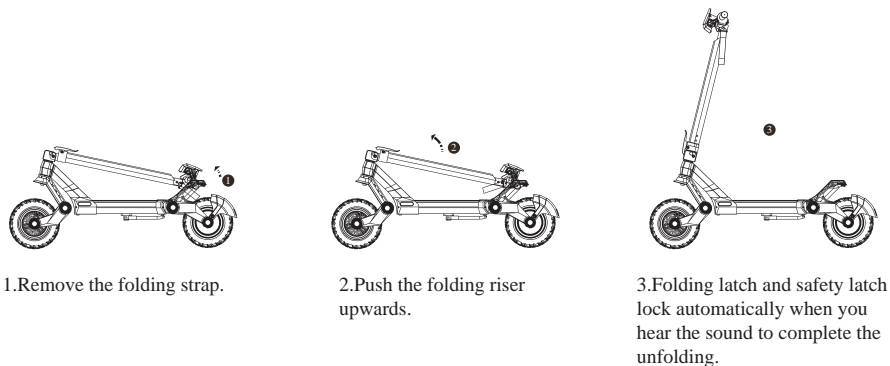

7. Tips for beginners

- ⚠ Wear protective devices, including qualified helmet, knee pads, wrist pads, and elbow pads.
- ⚠ Practice riding until you can easily get on, move forward, make a turn, stop and get off the electric bike.
- ⚠ Avoid run over anything that may cling onto or get stuck in wheels.
- ⚠ A wide road is preferred; do not ride the electric bike on a slope, pedestrian or a road with obstacle on until you are proficient in riding the bike.

8. Operation instruction

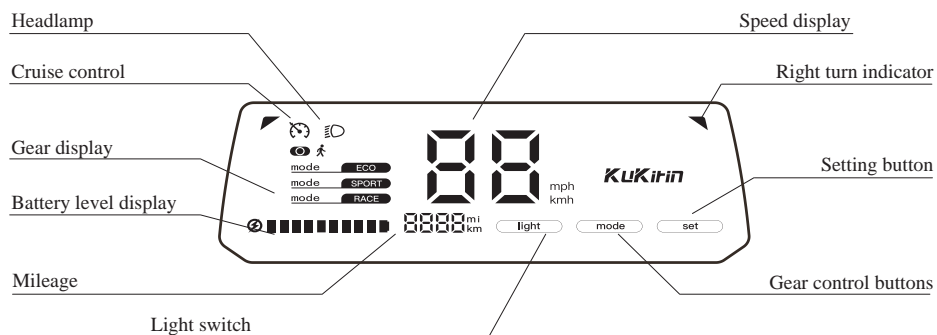
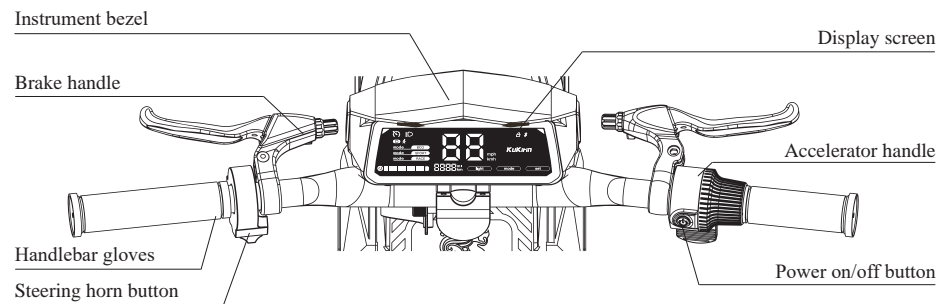

Set: Setting touch button, click to switch speed and mileage unit, long press to switch zero start non-zero start.
 Mode: Mode touch button, click to switch riding mode, long press to turn on/off cruise control.
 Light: Headlight touch button.

Multi-function button: Wake up with a single click under dormant state, switch on/off the light with a single click under normal condition, and double click to switch the riding mode.

Turn signal switch: When the turn signal switch is toggled to the left to enter the left turn, the left turn signal light flashes; when the turn signal switch is toggled to the right to enter the right turn, the right turn signal light flashes.

Horn button: Press the horn button horn sounds.

9. Troubleshooting

Malfunction	Code	Solutions
Block	E0	Make sure the wheel is not stuck and restart.
Overpressure	E1	Replacement battery.
Undervoltage	E2	Check battery/charge.
Controller failure	E3	Retry after replacing the controller.
Throttle malfunction	E4	Unplug the terminal of the throttle/restart.
Brake failure	E5	Unplug the terminals of the brake/restart.
Serial communication failure	E6	Change lamp board/controller.
Hall failure	E7	Check 3 phase wires/change motor/change controller.

10. Battery charging

! Friendly reminder: When charging, the charger indicator light is red; it turns green when fully charged.

Open the waterproof plug for charging

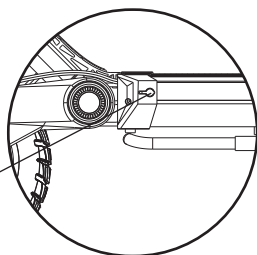

11. Maintenance

! Lubricating oil: Every six months, a small amount of white lubricating grease or lubricant needs to be added to the folded area for maintenance. The scooter should be inspected every three months to see if any screws are loose. If any are loose, please tighten them.

! Battery: When the scooter is charging or not in use, please turn off the power. When it is not in use for a long time, the electric scooter should be placed in a safe location and charged at least once every 3 months.

! Storage: Please do not leave the scooter in scorching sun or other severely humid areas for a long time. Please keep the scooter clean.

12. Warranty

From the date of receipt to the warranty period, if this product occurs malfunctions or is damaged, it can be repaired, exchanged, or returned for free after being tested and confirmed by the KuKirin after-sales center. When applying, please contact the product seller and follow the instructions. At that time, you need to provide accurate, complete, and valid purchase information or invoices.

Warranty content	Warranty period
Controller, instrument, motor, lithium battery, charger.	Half a year
Frame, front body, rear wheel hub, brakes, folding, body lever, front fork, brake system, throttle dial, etc.	1 year

13. Warranty Card

Please fill in the following information clearly and completely when servicing the product.

User Information	Name	
	Email	
	Mailing Address	
	Contact Phone Number	
Product Information	Product Name	
	Product Specifications	
Retailer Information	Name	Shenzhen KuKirin Technology Co., Ltd.
	Address	4F4913, ShenZhou Computer Building, Madame Curie Avenue, Vanke City Community, Bantian Street, Longgang District, Shenzhen City.

! Due to the continuous improvement of product functions, design changes, etc., this manual may be inconsistent with the product you purchased. Please refer to the actual product.