

# Sofirn SC33 Manual

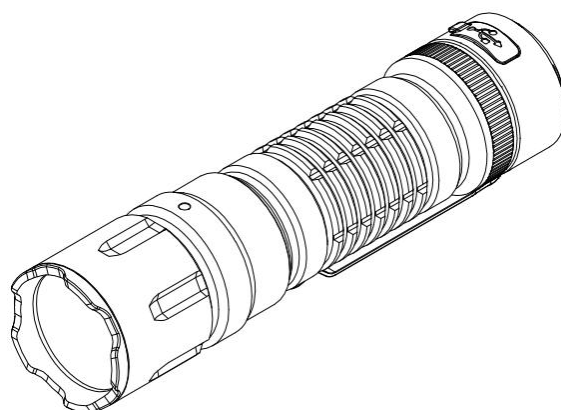

**Thank you for purchasing this SOFIRN product.  
Contact us@sofirnlight.com or eu@sofirnlight.com if you need assistance.**

SOFIRN SC33 flashlight is a small EDC light that delivers a stunning output of 5200 lumens and a beam distance of 327 meters. The light features a tail e-switch that allows you to easily access different modes and functions. It is powered by a rechargeable 21700 battery that can be charged via a USB-C port. The SC33 flashlight also has a long runtime of up to 11.5 hours on low mode (300-lumen). Whether you need a flashlight for camping, hiking, emergency, or everyday use, the SC33 flashlight is a reliable and versatile choice that won't let you down.

## ANSI/NEMA FL1 Chart

Mode	Moonlight	Eco	Low	Medium	High	Turbo
Luminous Flux [lm]	10	50	300	750	1800	5200
Runtime [h]	300	45	11.5	5.3	1.85	1.5
Beam Distance [m]	15	31	75	120	189	327
Peak Intensity [cd]	53	243	1417	3617	8900	26750
Impact Resistance	1m / 3.28 ft.					
Water Resistance	IP68 (not for diving)					

<b>Notes</b>	The above mentioned parameters are based on tests according to international flashlight testing standards (ANSI/NEMA FL1) using one 5,000mAh 21700 Li-ion battery in our laboratory. Results may vary with different battery or under different environmental conditions.
--------------	---

## Specifications

- ❖ Emitter: a Cree XHP70.3 HI led with a lifespan of 50,000 hours
- ❖ Operating voltage: 3V – 4.2V
- ❖ Battery options: 1 x 21700 rechargeable lithium-ion battery
- ❖ Dimension: 131 mm × 32 mm
- ❖ Weight: 110 grams (without battery)
- ❖ Flashlight body: AL6061-T6 aluminum alloy.
- ❖ Toughened mineral glass lens
- ❖ Orange peel reflector
- ❖ Tail e-switch
- ❖ Boost driver
- ❖ Water resistance i.a.w. IP68
- ❖ Mode Memory: memorizes the last brightness level used in the general modes (Eco/Low/Medium/High).
- ❖ Charging specification: 5V/2A
- ❖ Reverse polarity protection from improper battery installation.
- ❖ Low voltage warning: When the battery voltage is lower than 3.2V, the LED indicator will start to flash red. Please recharge the flashlight or insert a new battery.
- ❖ Low voltage protection: It turns off automatically if the voltage gets too low. Please recharge the battery or insert new batteries.
- ❖ Advanced Temperature Regulation (ATR) technology: When the flashlight is turned on for a certain period of time, the temperature will drop.

## Battery Specifications

Battery Type	Dimension & Quantity
Rechargeable lithium-ion battery	21700 x 1

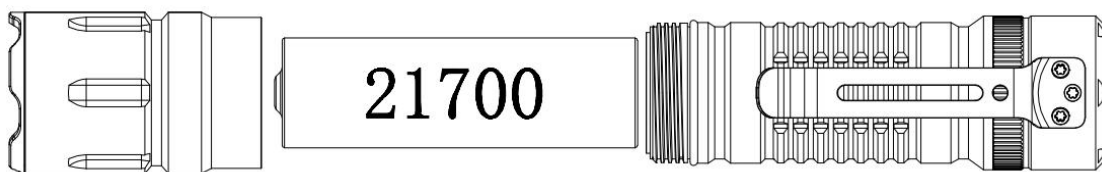

## Battery Installation

Before first use, please unscrew the flashlight and remove the insulating sticker. If the battery needs to be replaced, please make sure that the positive end of the new battery faces the flashlight's head when you put the battery in.

## Battery Level Indicator

The indicator shows the power status for 5 seconds after you turn on the light.

**Green** = remaining battery power is on 75%-100%.

**Flashing Green** = remaining battery power is on 50%-75%.

**Red** = remaining battery power is on 25%-50%

**Flashing Red** = critical power (less than 25%), please replace or recharge battery as soon as possible.

## Charging

SC33 offers a USB type-C charging port for convenient charging. It takes approximately 2.5 hours to fully charge the flashlight with a 5V/2A charger (not included). While charging, the indicator flashes in red. It turns green when it's fully charged.

## Operation Instructions

### STEPPED RAMPING:

**ON/OFF:** One-click the switch to turn the light on/off.

**CHANGE BRIGHTNESS LEVEL:** When the flashlight is on, press and hold the switch and it will start from the present brightness level, automatically cycle through Eco, Low, Medium, and High. The mode is selected when the switch has been released. (Please note: moonlight, turbo and strobe modes are not in the automatic cycle).

**DIRECT ACCESS TO TURBO MODE:** When the flashlight is on/off (not in lock mode), quickly double-click the switch to activate Turbo mode. Double-click again to cycle Moonlight-Turbo.

**DIRECT ACCESS TO STROBE MODE:** When the flashlight is on/off (not in lock mode), quickly triple-click the switch to enter into Strobe. Then triple-click the switch to cycle through Strobe-SOS-Beacon, one-click the switch to return to previously used mode.

**LOCK/UNLOCK:** When the flashlight is off, 4 fast clicks on the switch to lock the

flashlight. The light blinks twice to signal that the light is in lock mode. Fast two, three or four clicks on the switch to unlock it returning to previously used mode. You can only access to momentary-moonlight by holding the switch while being locked. The light will flash twice to indicate the flashlight is in lock mode when you try other operations.

**DIRECT ACCESS TO MOONLIGHT MODE:** When the flashlight is off (not in lock mode), hold the switch for over one second to enter into Moonlight. Then one click to turn off or hold the switch again to enter Low cycling through Eco, Low, Medium, High.

**AUTOMATIC LOCKOUT:** When the flashlight turns off after 1 minutes, it will automatically enter lock mode. Fast two, three or four clicks on the switch to unlock it returning to previously used mode. You can only access to momentary-moonlight by holding the switch while being locked. The light will flash twice to indicate the flashlight is in lock mode when you try other operations.

### **SMOOTH RAMPING**

**ON/OFF:** Single click the switch to turn the light on/off.

**RAMPING UP/DOWN:** Hold and press the switch to change brightness steplessly. Ramping changes its direction when the switch is being pressed again within 1.5 seconds. The light flashes once when it reaches the lowest or highest end of the ramp. Other operations are the same as stepped ramp.

### **SWITCH BETWEEN STEPPED RAMPING AND SMOOTH RAMPING**

While the flashlight is on, fast four clicks to switch between stepped ramping and smooth ramping. The light blinks twice to signal that the switch is completed.

## **Safety Instructions**

- ❖ SC33 is a powerful flashlight. Never point it directly at a person, animal or moving vehicles. Doing so could cause retinal damage. Please do not allow children to play with it. Strobe mode may cause seizure in persons with photosensitive epilepsy.
- ❖ Operating SC33 for a long time in high powered modes will quickly heat up the flashlight. This is normal.
- ❖ Pay close attention to the proper installation of the battery. Always check that the positive end of the battery faces the flashlight's head.

- ❖ Please unscrew the light body half a turn to avoid unwanted activation during transport. It also prevents the battery from draining while the flashlight is in standby.
- ❖ Avoid hitting or dropping the flashlight.

## Troubleshooting and Maintenance

- ❖ Disassembling the sealed head can damage the flashlight and voids the warranty.
- ❖ Sofirn, Ltd. recommends using high-quality brand batteries. Damage by battery leakage voids the warranty.
- ❖ Remove the battery if the flashlight will not be used for an extended period of time.
- ❖ To prevent self-discharge or accidental activation during storage or transportation, unscrew the light body by half a turn or remove the battery.
- ❖ Every 6 months threads should be wiped with a clean cloth followed by a thin layer of silicone grease.
- ❖ To maintain a proper level of waterproofness, replace worn-out o-rings with an approved spare.
- ❖ Troubleshooting: Clean battery contacts regularly as dirty contacts may impair the performance of the flashlight. If you experience problems (flicker, shine intermittently or failure turn on) the following root causes and solutions should be tried:

Reason A: The battery needs a replacement.

Solution: Replace the battery with an approved type of a fully charged battery.

Reason B: Threads, PCB board contact or other contacts are dirty.

Solutions: Please clean the contact points with a cotton swab soaked in rubbing alcohol.

Reason C: The flashlight will not turn on upon first use.

Solution: Please do not forget to remove the insulation sticker from the battery on first use.

If the above methods do not work please refer to the warranty policy before contacting your authorized distributor.

### **Sofirn Limited:**

Tel: +86-755-23440047 Fax: +86-755-23440141

Web: [www.sofirnlight.com](http://www.sofirnlight.com)

E-mail: [us@sofirnlight.com](mailto:us@sofirnlight.com) [eu@sofirnlight.com](mailto:eu@sofirnlight.com)

[wholesale@sofirn.cn](mailto:wholesale@sofirn.cn)

**Please contact us if you have any questions.**

**If your product is defective please contact us for replacement within warranty period.**

Manufacturer: Shenzhenshi Jinba Technology Co.,Ltd

Address: 1/F to 9/F, 1st Building, NO.110 Tenglong Industrial Center, Guanlan Street,  
Longhua New District, Shenzhen 518000, China