

**ATUMTEK Single Monitor
Gas Spring Desk Mount Stand**

WARNING STATEMENTS

Warning



Prior to the installation of this product, the installation instruction must be read and completely understood. Failure to do so may result in personal injury, property damage or voiding of factory warranty.



Do not install on a structure that is prone to vibration, movement or chance of impact. Reinforce the structure as required before installation. Don't use the product on particle board.









Pay attention to the weight capacity of the mount. Exceeding the limitation can result in function unworkable or even serious personal injury and property damage.



Never operate the mount if parts are missing or damaged. Contact your local service center for warranty service.

PARTS INCLUDED

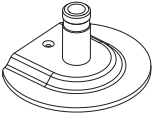
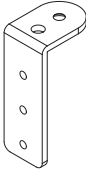
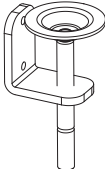
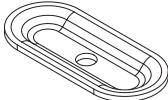
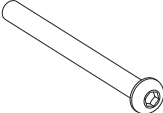
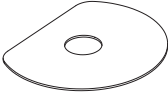
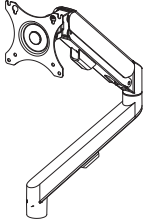
| | | | |
|---|---|---|---|
| <p>A</p>  <p>M8×16 (×1)</p> | <p>B</p>  <p>M6×10 (×2)</p> | <p>C</p>  <p>M5×10 (×4)</p> | <p>D</p>  <p>M4×10 (×4)</p> |
| <p>E</p>  <p>(×4)</p> | <p>F</p>  <p>4MM (×1)</p> | <p>G</p>  <p>5MM (×1)</p> | |
|  <p>1 (×1)</p> |  <p>2 (×1)</p> |  <p>3 (×1)</p> |  <p>4 (×1)</p> |
|  <p>5 (×1)</p> |  <p>6 (×1)</p> |  <p>7 (×1)</p> | |

① Stand Base

② Clamp Connector

③ C-Clamp

④ Long Bolt Attachment Plate

⑤ Long Bolt

⑥ Anti-slip Pad

⑦ Gas Spring Arm

Step 1 Mount the Base on Desk

Desk Side Installation (Desk Thickness ≤ 8 cm.)

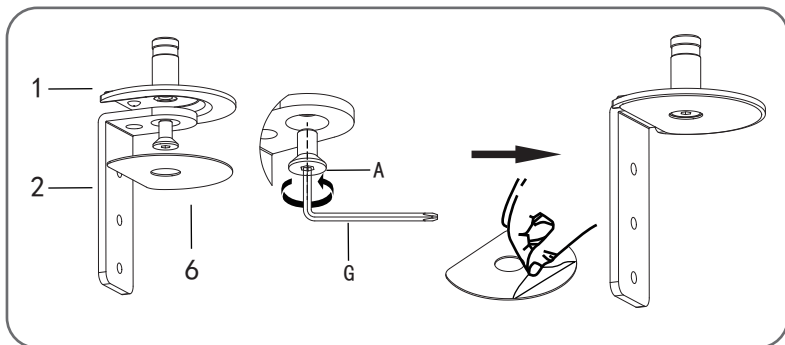

First install and fasten the clamp connector (2) under stand base (1) together, then stick anti-slip pad (6) under them.

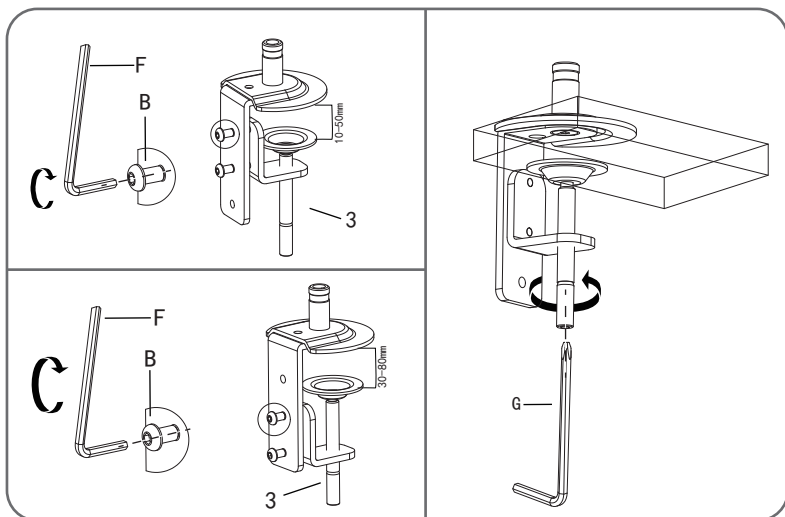

Now assembly the clamp connector with C-clamp (3) together. There are 2 positions to choose. Finally mount the stand base on desk side and fasten it.

OR

Desk Grommet/ Hole Installation (Desk Thickness ≤ 6 cm.)

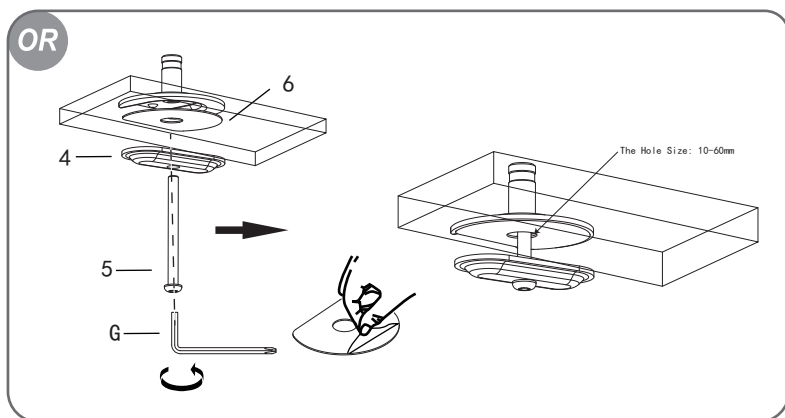

For desk with grommet hole or hole, stick anti-slid pad under stand base, then attach PARTS (4) and (5) together, finally fasten the bolt to mount the base on desk.

Step 2 Mount the Arm

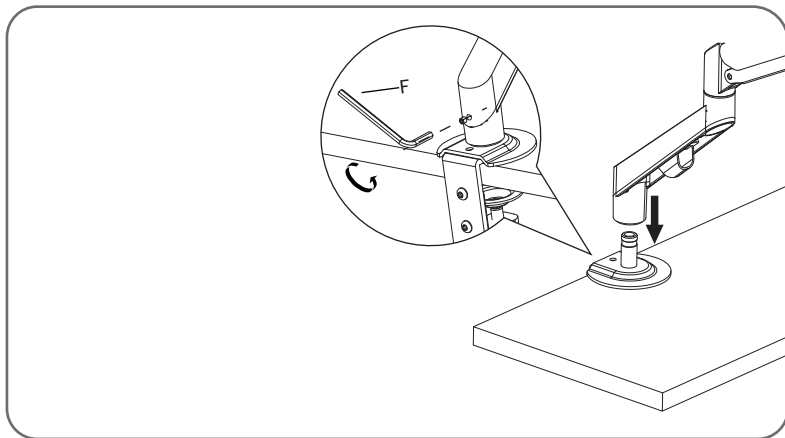

Mount gas spring arm on the base and tighten the screw to fasten monitor arm on stand base firmly.

Step 3 Install the Monitor on Gas Spring Arm

Install 2 screws (C/D) and washers (E) on the upper VESA mounting holes first.

* only half screw the screws on so that monitor can be hung on VESA plate safely.

Then hang the monitor on arm and fasten the top 2 screws, finally install the lower 2 screws on firmly.

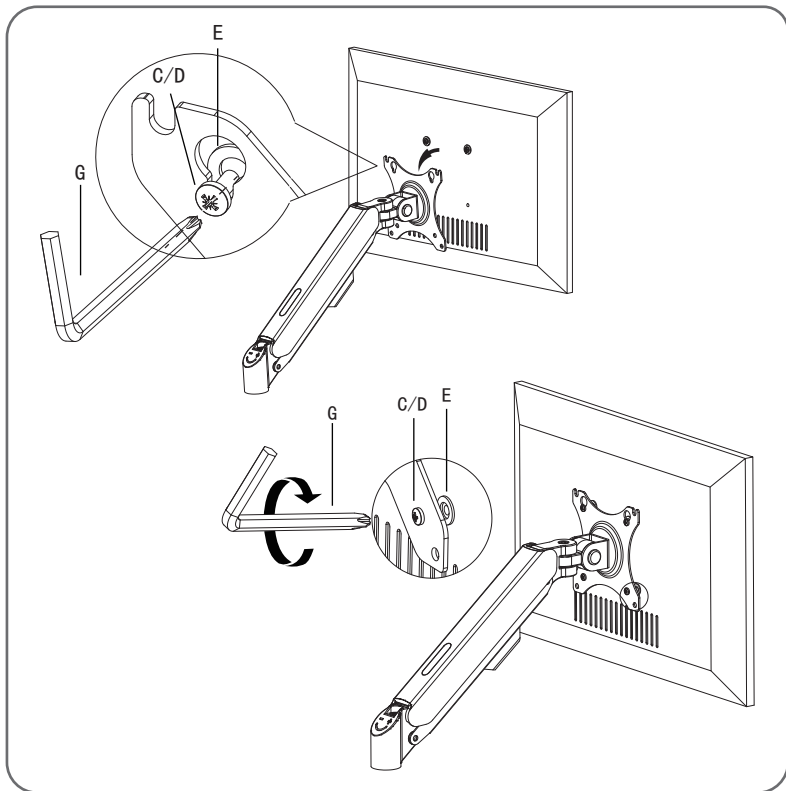

NOTE:

1. Please avoid excessive tightening screws and damage the monitor.
2. If monitor mounting head is not in upright direction, install monitor on arm first, then rotate monitor to upright direction.
3. Choose to use washers or not according to monitor.

Step 4 Adjust the Arm

Keep the arm in horizontal position, then use the hex wrench to adjust the height tension of the gas spring arms, to ensure the arm can support different monitors horizontally at any position.

* Be sure to keep the arm in horizontal position during adjustment. Otherwise, it would be difficult to adjust the mount.

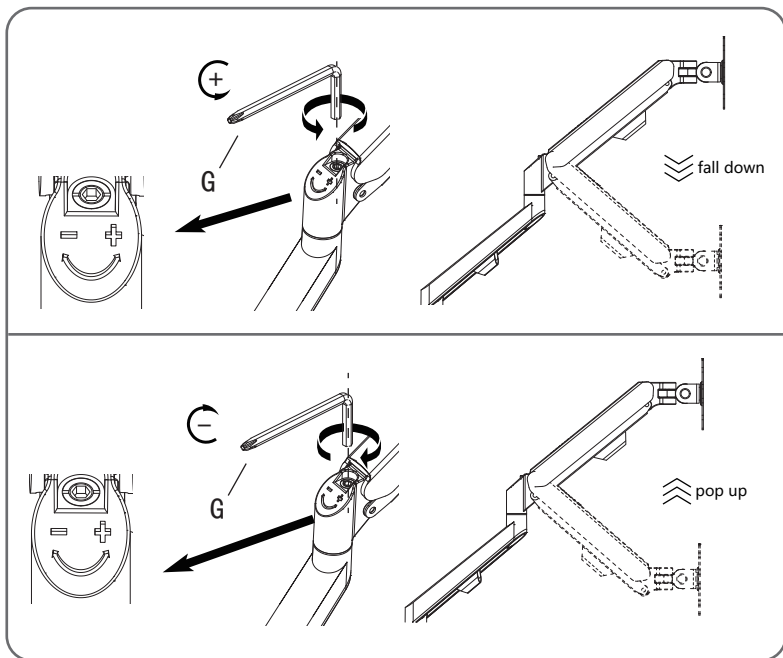

NOTE:

Increase the tension in "+" direction if the arm automatically sags.

Decrease the tension in "-" direction if the arm automatically rises.

Step 5 Cable Management

Insert cables management covers on arm to hold cables.

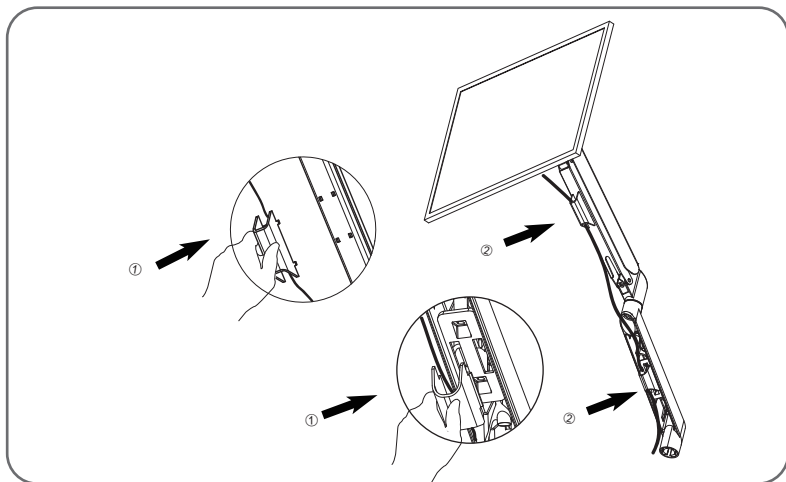

Step 6 Adjust Flexibility and Free Rotation

If it's too tight or too loose to rotate or tilt monitor, adjust the screws on monitor mounting head to reduce or increase damping to enable free rotation.

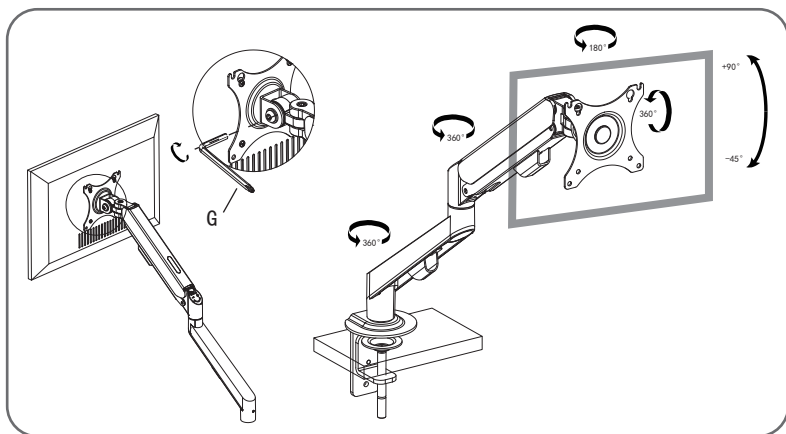

ATUMTEK

Contact us via Facebook Messenger (Recommended):

m.me/atumtekproducts

OR

www.atumtek.com

OR

support@atumtek.com

If you find our product satisfactory,
please encourage us by sharing your user experience online.
If you need help with this purchase, please do not hesitate to contact us.



Prolinx GmbH
Brehmstr.56, 40239 Duesseldorf Germany



Syncwire UK Ltd
C/O Lai and Co.109 Portland Street, Manchester, M1 6N