



KUKiirin G3 Pro

USER MANUAL

EN



www.kugookirin.com

KUKiTiN G3 Pro SCOOTER USER MANUAL

KUKiTiN G3 Pro Scooter User Manual

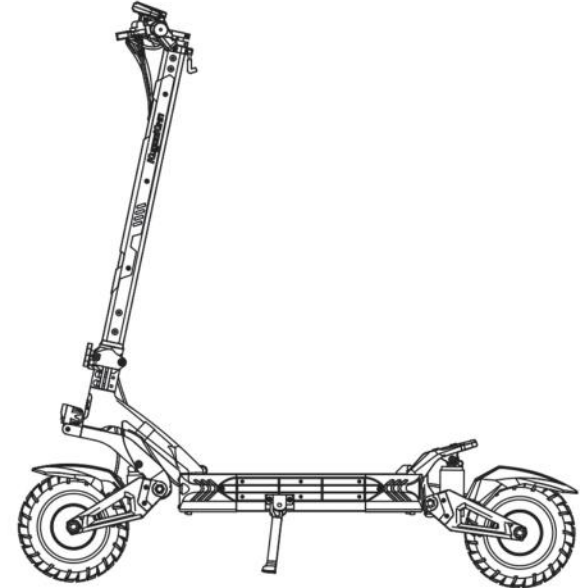

KUKiTiN Words and trademarks are trademarks or registered trademarks of our company, other companies mentioned. Product or service names may be trademarks or registered trademarks of their respective owners. The enterprise belongs to the company, all rights reserved.

The pictures are for reference only, please read the product instruction manual before using the product - the warranty card is included

WELCOME TO USE

THANKS YOUR CHOOSING KUGOOKIRIN G3 PRO SCOOTER, EXPERIENCE THE JOY OF ELECTRIC SCOOTERS .

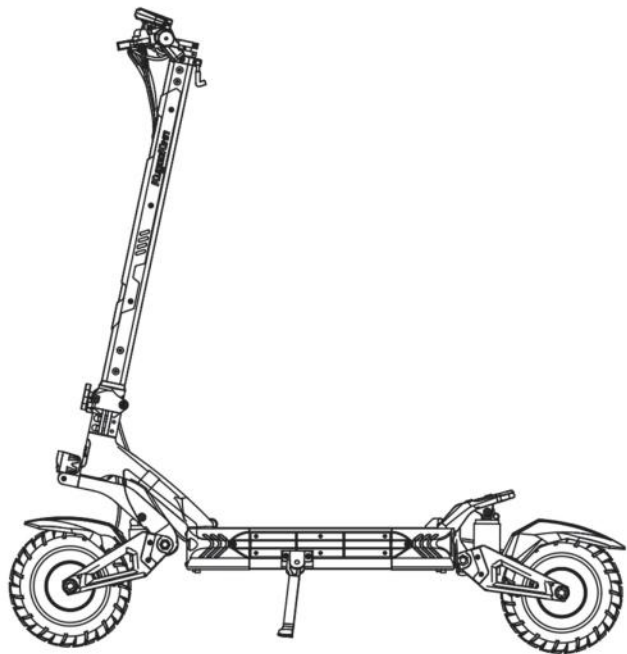

CATALOG

1. PRODUCT & ACCESSORIES	3
2.FUNCTION INTRODUCTION	4
3.SAFETY INSTRUCTION	5
4.PRODUCT DISPLAY	9
5.SCOOTER ASSEMBLY	10
6.EXPAND STEPS	11
7.FOLD STEPS	12
8.CHARGING	13
9.TRANSPORTATION	13
10.BUTTON FUNCTION	14
11.PASSWORD MODIFICATION METHOD	15
12.BASIC OPERATION	16
13.OPERATE INSTRUCTION	17
14.RIDE INSTRUCTION	18
15.BATTERY &CHARGER	19
16.LED DISPLAY	20
17.MAINTENANCE	22
18. NORMAL PROBLEM AND SOLUTION	23
19.PARAMETER SETTING	24
20.AFTER-SALE SERVICE	25
21.PRODUCT WARRANTY INFO	26
22.WARRANTY CARD	27

1 PRODUCT&ACCESSORIES

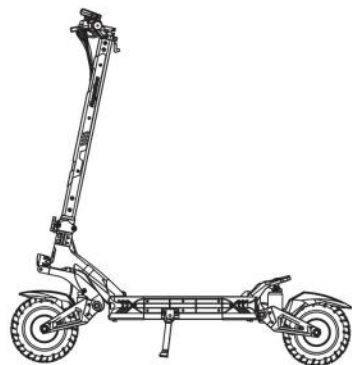

ACCESSORIES



User manual



Inflator



Tool bag & screws

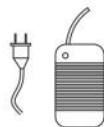

Charger

Please carefully check whether the items in the box are complete and intact, if there is any missing or damaged, please contact the seller.

2 FUNCTION INTRODUCTION

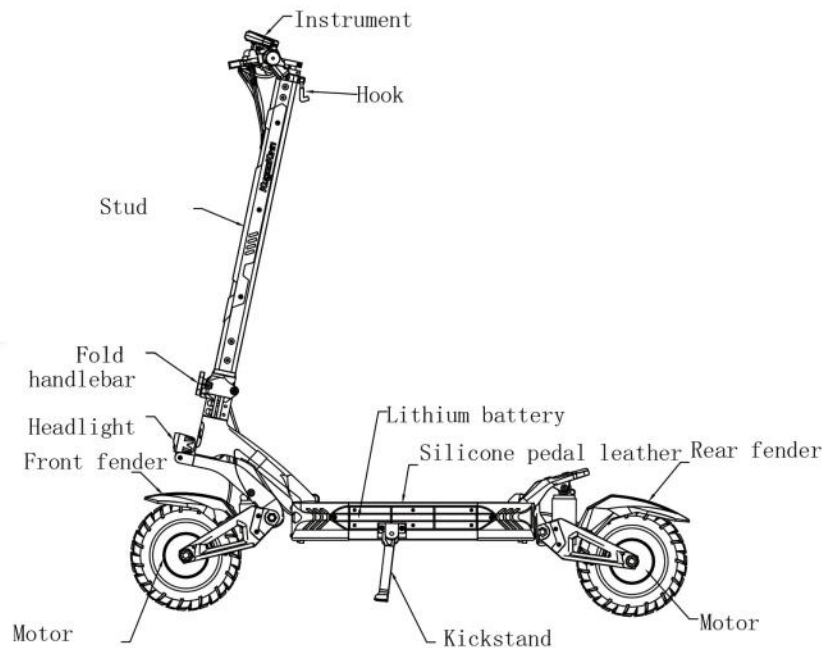

3.SAFETY INSTRUCTION

Note:Please read the following important safety informationcarefully before use and follow it.

1.This electric scooter is for anadult use,please not carry others at the same time.

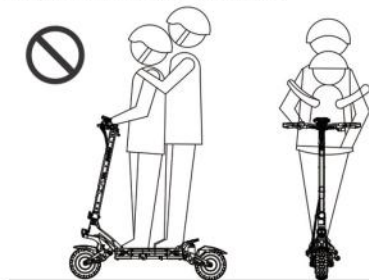

2.When you riding the electric scooter,please wear the hemlet and other guard tool.

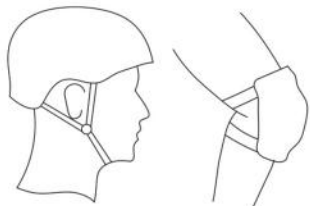

3.Please don't ride this product in an unsafe or illegal location.

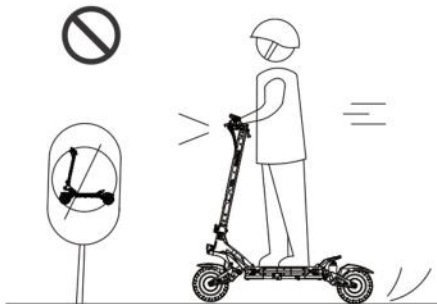

4.Please practice in an open space first, and then ride on the road after you are proficient in the operation.

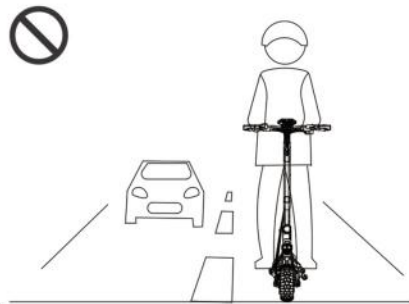

05

5.Do not do dangerous actions or ride with one hand while the car is running,and keep both feet on the pedals.

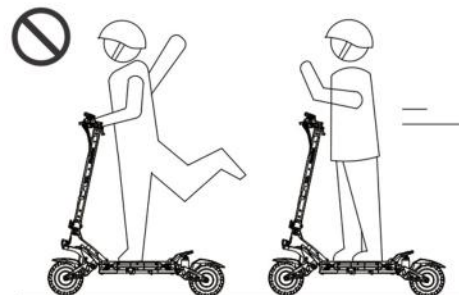

6.Please don't try to go directly through the steps with a gap of more than 30cm, which may cause the car to overturn. Injury to the driver or damage to the car should be avoided as much as possible for steps below 30cm.

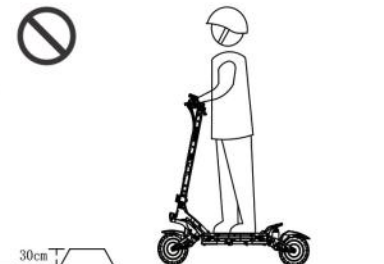

7.For your driving safety, please control the speed within 25KM/H. Please try to avoid riding at night. If you ride, please turn on the lights and control the speed to 15KM/h or below.



8. Please don't use this product in an environment below -5 degrees.



06

9. In case of uneven road surface or poor road conditions, please slow down and drive carefully or get off the vehicle.

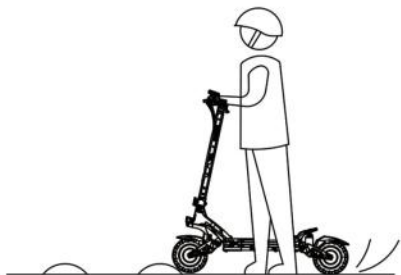

11. Please don't immerse the product in a water depth of more than 4CM to avoid damage to the electrical parts of the vehicle due to water ingress.



10. Please don't ride this product on slippery roads (such as water, ice, oil, etc.).



12. In bad weather such as rain, snow and strong wind, please try to avoid riding to avoid unnecessary personal injury.

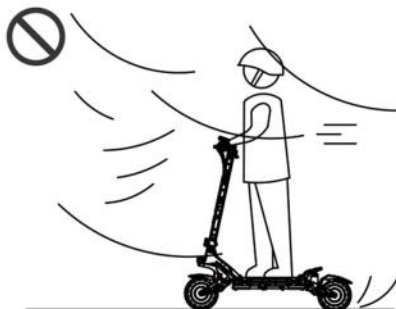

13. The user should use the product in accordance with the relevant instructions of the product in the product manual, and should not exceed the load that the product can bear.

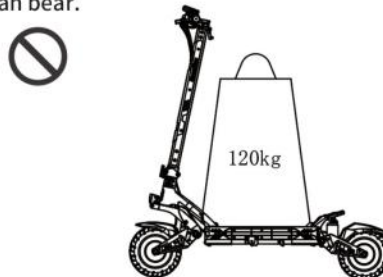

15. Electric scooter is special riding product, Please try to ride on a smooth road with no potholes.



14. Please avoid using or placing it in a high or low temperature environment. Please do not put this product together with flammable items, so as to avoid a fire in extremely accidental circumstances.

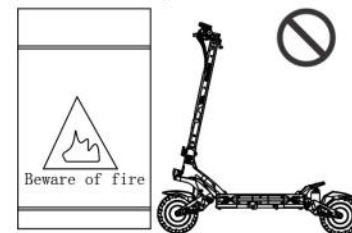

16. Users should ride in strict accordance with the traffic roads, and if there are special local laws and regulations, they should ride legally in accordance with local laws and regulations.

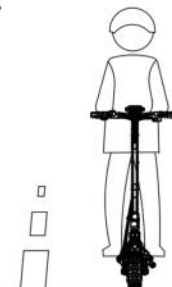

4. PRODUCT DISPLAY

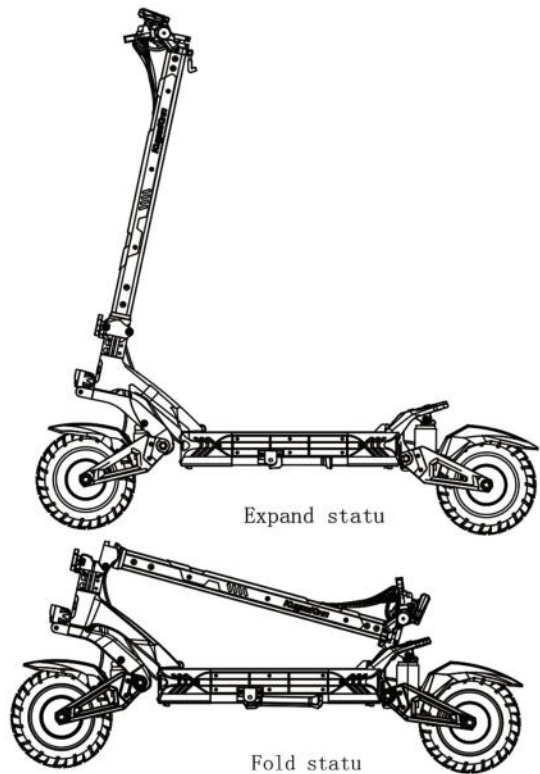

5. SCOOTER ASSEMBLY

1. Unfold the scooter and open the parking bracket to unfold the scooter (refer to 6 unfolding steps) .
2. Straighten the body bar and apply force forward.

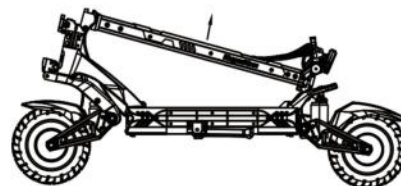

3. Confirm that the spring pin is back in place, and turn the handle to the right to tighten.



4. Use the tools included in the package to tighten the screws, and check if the power switch is working properly after assembly is complete.

Use the tool included with the package to tighten the screws.

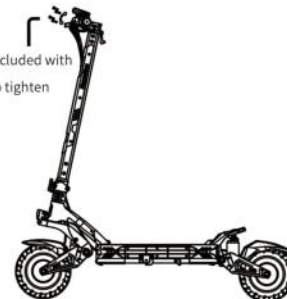

6. EXPAND STEPS

1. Press down on the hook with one hand and pull up the body bar with the other

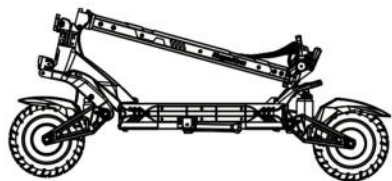

2. Pull the body bar up

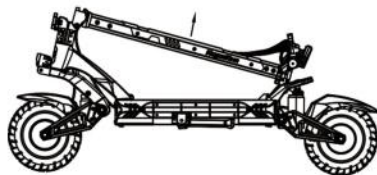

3. Straighten the body bar and apply force forward

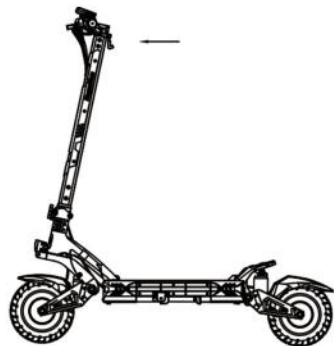

4. Confirm that the spring pin is back in place and turn the handle to the right to tighten.



7. FOLD STEPS

1. Holding the pole in hand, turn the handle to the left (counterclockwise)



3. Put lower body bar

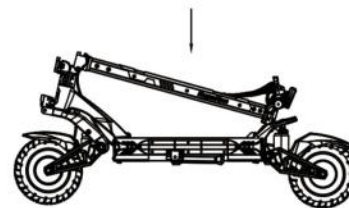

2. Hold the pole with one hand and pull the spring pin outward with the other .



4. Adjust the body bars to make sure the hooks fit into the slots and snap into place.

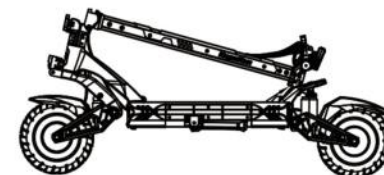

8.CHARGING

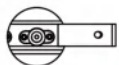

Open the charging port waterproof plug



connect charger



After charging,
fasten the
waterproof plug



1.Open the waterproof plug of the charging port and insert the charger connector into the charging hole on the body.

2.Insert the charger power plug into a power outlet.

3.When the indicator light of the charger is red, it means charging, and when the indicator light of the charger turns green, it means that the battery is fully charged, and fasten the waterproof plug.

9.TRANSPOTATION

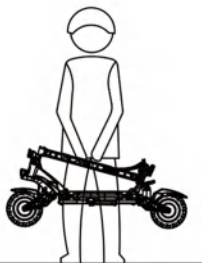

When folded you can carry the scooter with one or two hands.

10.BUTTON FUNCTION

- 1.Insert the key,turn thr key to right to power on.
- 2.Press and hold the function switch button to switch the machine on and off
3. Short press the function switch button once after power on to switch gears, divided into three gears.
4. Short press the single-drive switch once after power on to switch between single-drive and dual-drive modes.
5. After power on, press the function switch button three times in a row to enter the menu setting interface, the meter
P1, P2, P3, P4, P6, P7, P8, Pa, Pb, Pc will be displayed.
P1: km/mile selection setting, default km
P2: Voltage level setting: 36V/48/52/60V/72V
P3: Wheel diameter: unit, inch; can be set to 080-160 (080 means 8 inches, 100 means 10 inches, and so on), each time increases by 5
P4: Number of magnetic poles for speed measurement: range: 1-100, default 30
P5: Cruise selection: 0 means no cruise navigating, 1 is cruising. When the cruise is not turned on, the cruise icon does not light up; when the cruise is turned on, the cruise icon flashes; after the 8S enters the cruise, the cruise icon flashes; the default is not to cruise
P6: Zero startup, non-zero startup settings, 0: zero startup; 1: non-zero startup, the startup mode will be displayed when starting up (zero startup will not display an icon, non-zero startup will display NON); The accelerator starts directly; in non-zero start mode, you need to slide the car above 5KM/h and press the accelerator to start.
P7: speed limit setting: range 0-100 percent speed limit
P8: Sleep time setting: 0, no sleep; other numbers are sleep time, range:1-60; unit minute, default 5 minutes PA: Start strength setting: 1-5, 1 minimum, 5 maximum PB: Brake strength setting: 1-5, 1~20%, 2-35%, 3-50%, 4~70%5~100% When P1 is displayed, 0-km or 1-mile will be displayed below, indicating the optional setting of km/mile; long press the power button for 3 seconds, the value will flash; at this time, short press the power button to select 1-mile or 0- km; when 0-km is displayed, select km, and Km/h will be displayed; when 1-mile is displayed, select mile, and mile will be displayed; then long press the power button to exit, and select other parameters for debugging; if there is no operation for 8 seconds Automatically exit the parameter setting (other parameter settings are the same); after entering the menu setting, if the currentparameter does not need to be modified, press the button once and switch to the next parameter setting interface, such as the current P1, if you do not need to modify the setting To modify P1, then short press the button once to switch to P2.

11.PASSWORD MODIFICATION METHOD



1.Original password is 000,Align the tick marks

2.Press the hole with a pointed object, then modify the password you want to set, and then release it, the password setting is completed.

12.BASIC OPERATION

- A . Power button B.Single &double driver switch C.Throttle D.Handlebar cover
E.Instrument F.Brake G.Headlight switch H.Side light switch I.Horn
J.Function switch button

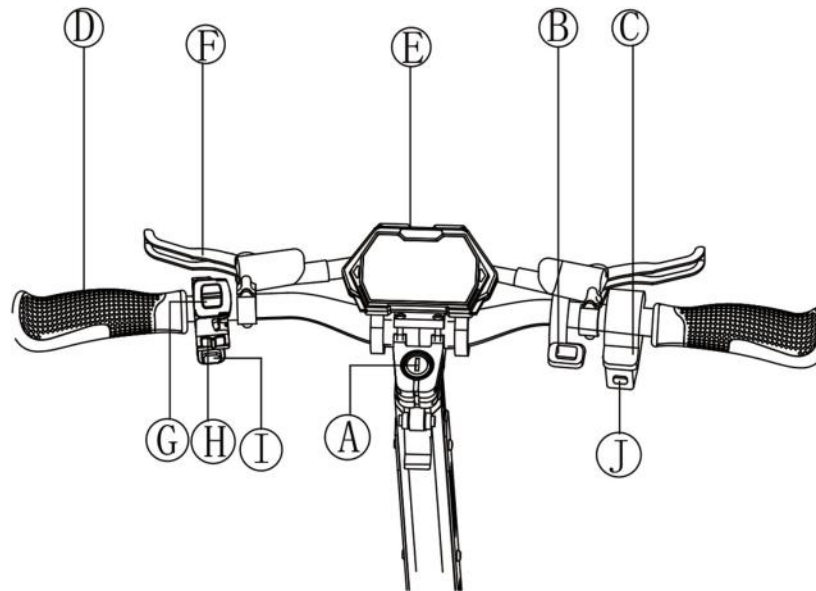

13. OPERATE INSTRUCTION

TURN ON AND TURN OFF

Insert the key, turn the key to the right to power on, press and hold the function switch button for 3 seconds to turn on the vehicle, and long press the function switch button for 3 seconds to turn the key to the left to turn off the vehicle.

GEAR SETTING

Press once the function change button, the setting range is 1st gear, 2nd gear and 3rd gear.

BRAKE CONTROL

The greater the pressure on the brake lever, the greater the braking force.

LED HEADLIGHT SWITCH

In the power-on state, push the headlight switch key up to turn on the headlights.

EMERGENCY BRAKE

When encountering an emergency, use your fingers to hold the brake lever tightly, at this time, the rear wheel friction braking can be realized at the same time. Under normal circumstances, please do not use the emergency brake after vigorously driving at high speed, so as to avoid damage. The company is not responsible for the damage caused by riding risk or damage to the rear wheel, and it needs to be repaired at a fee.

CRUISE CONTROL

When entering into the cruise control mode, repress the throttle or press brake can withdraw to cruise control. If need to turn off the cruise mode, enter the menu setting interface and set P5 to 0.

14. RIDE INSTRUCTION

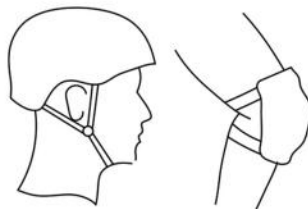

RIDE PREPARATION

1. Choose a venue suitable for riding.
2. Unfold the product according to the unfolding instructions and wear protective gear.

BEGAIN TO RIDE

1. Insert the key, turn the key to the right to power on, long press function switch button for 3 seconds to turn on the scooter.
2. One foot put on the pedal, another put on the ground.



3. After turning on, under the zero start mode, press throttle to turn on directly. Under the Non zero start mode, need to slide the scooter over 5KM/H and then press throttle to turn on. Slowly press the accelerator, and the car will move forward slowly. After driving smoothly, put the foot on the ground at the same time, and press the right thumb accelerator. The larger the angle, the faster the speed of the car.

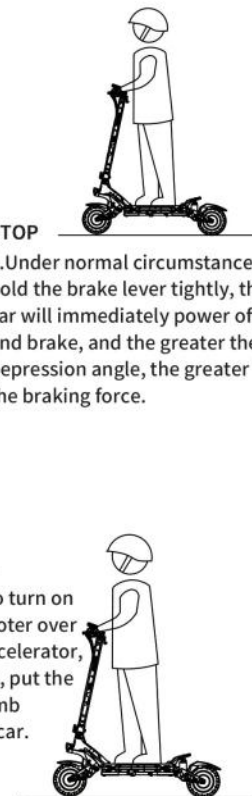

STOP

1. Under normal circumstances, hold the brake lever tightly, the car will immediately power off and brake, and the greater the depression angle, the greater the braking force.

15. BATTERY & CHARGER

Every **GS Pro** Electric scooters are equipped with dedicated lithium batteries and dedicated smart chargers. Each scooter and its accessories have a special number, please do not use other chargers to charge, and other types of products should not be charged with the company's chargers. The company is not responsible for any damage to the battery or charger caused by this.

BATTERY



THE LITHIUM BATTERY PROVIDED BY KUGOOKIRIN CAN BE RECHARGED WITHIN 600 TIMES WITHOUT ANY CHANGE IN CAPACITY; MORE THAN 600 TIMES, THE CAPACITY WILL SLOWLY DROP TO 80%; NORMAL USE CAN GENERALLY REACH MORE THAN 1000 TIMES, THE LITHIUM BATTERY MAY BE DANGEROUS WHEN CHARGING, PLEASE CHARGE IT OUTDOORS.

CHARGER



The special chargers provided by KugooKirin have charging protection function. When the battery is 100% full, it will automatically power off. The charging time of the 2A charger is about 10 hours, the charging time of the 3A charger is about 7 hours, and the charging time of the 5A charger is about 4 hours. Damage to the battery due to abnormal factors such as water, collision, etc. is not covered by the warranty policy.

16. LED DISPLAY

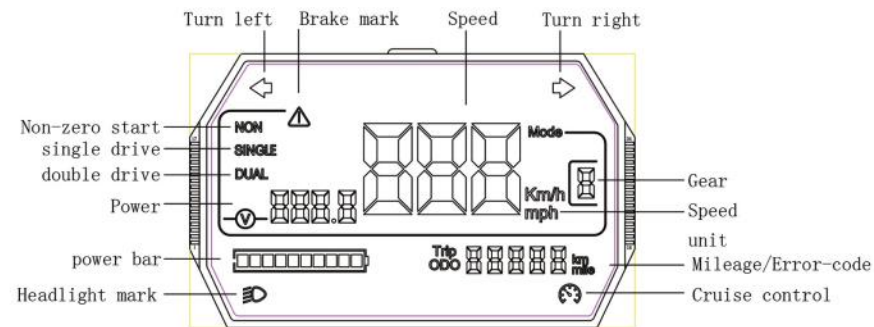

ERROR CODE

There are warning lights flashing, and the value displays E001-E017 and flashes

Fault	code	Solution
Rear motor haul fault	E-001	Swap the front and rear motor heads to see if this code still appears. If it still appears, the controller is faulty. Replace the controller and try again; if it does not appear, replace the motor and try again.
Turn handlebar fault	E-002	Try again after changing the throttle.
Controller fault	E-003	Try again after changing the controller.
Under-voltage	E-005	The battery is low, try again after charging.
Receive fault	E-006	It belongs to the instrument receiving failure, please try again after replacing the instrument/controller.
Send fault	E-007	It belongs to the instrument receiving failure, please try again after replacing the instrument/controller.
Controller over temperature protection	E-009	The temperature of the controller is too high, check whether the controller is fixed/heated well.
Front motor haul fault	E-011	Swap the front and rear motor heads to see if this code still appears. If it still appears, the controller is faulty. Replace the controller and try again; if it does not appear, replace the motor and try again.
Secondary controller failure	E-013	Try again after changing the controller
Sub-controller receive failure	E-017	It belongs to the instrument sending failure, try again after replacing the instrument/controller.

17.MAINTENANCE

LUBRICANT

Every six months, you need to add a small amount of white grease or lubricant to the folded part for maintenance. Please check the scooter every three months to see if there are any loose screws. If they are loose, please tighten them.

BATTERY

When you get the electric scooter for the first time, please fully charge the battery before using it. The battery can be charged at any time to ensure that the battery has electricity. During this period, charging will not cause any damage to the battery. When the battery is not in use, please use it for 3 months charge once.

STORE AND DAILY CARE

Please do not leave the scooter in the hot sun or other severely damp places for a long time. Please keep the scooter surface is clean.

18.NORMAL PROBLEM AND SOLUTION

Possible phenomena and repair methods

- 1.Unable to turn onIt may be that the battery is dead, plug it in the charger to charge it, and then press the operation to turn it on and try again.
2. The brakes are relatively looselt may be that the brake fluid is not enough, add the brake fluid and try again
3. There is a fault code on the meterRefer to the manual for troubleshooting

19 PARMETER SETTING

Parameter	Product name	KuKirin G3 Pro electric scooter
	Product model	G3 Pro
Size	L*W*H	1295*630*1360mm
	After folding: L*W*H	1295*630*595mm
Weight	Net weight	About 40 KG
Statu	Max load	120 KG
Main parameter	Max speed	no-load approx 70 km/h, load approx 55 km/h
	Full power mileage	Range 80 (Depends on the environment. Angle. Speed. Driving habits, weight, etc.)
	G3 Pro speed data settings	idling, 25, 45, 70, load single drive: 25, 45, 55, load double drive:25, 45, 65.
	Max climbility	Single Drive 25° Dual Drive 35°
	Adapte range	Smooth and smooth pavement, the convexity of the pavement is less than 2cm, and the depression is less than 3cm
	Tire	10 Inch Off-road tire
	Shock absorber system	Front hydraulic shock absorber + rear hydraulic shock absorber
	Dustproof waterproof level	IP54
	Brake system	front rear oil brake+e-brake
	LED display	speed,mileage ,gear
	Light system	LED High Headlight
	Motor power	1200W
Charging parameter	Adapter rated input voltage	100-240V
	Lithium battery	23.2Ah
	Charging time	2A charger charging time is about 10 hours,3A charger chargingtime is about 7 hours,5A charger charging time is about 4 hours.

20 AFTER-SALES SERVICE

Warranty Statement

This product is within the warranty period from the time of your purchase. Under normally use, we have confirmed that the product is faulty and damaged due to quality problems. We will repair, replace or return it for you free of charge as the case may be. The warranty period starts from the first purchase of the product and is subject to the date of the invoice receipt. When applying for after-sale service, you need to provide an accurate, complete and clearly filled valid sales invoice.

The following circumstance are not in the scope of free maintenance: (a) Misuse, abuse or improper transportation, maintenance or storage, including but not limited to use, storage or conservation under inappropriate temperature humidity or other inappropriate environmental conditions.

(b) Force majeure or unexpected events and other non-human controllable events

(c) Non-authorized personnel of the company repair or dismantle without authorization

(d) any third party products or services; (e) use the product for a purpose other than the specified or intended purpose; (f) use in other ways that violate the product's instructions for use;

(g) use the product for commercial purposes

(h) The accumulated mileage of the vehicle body record has exceeded 2,000 kilometers. Normal wear or aging, scratches, and problems caused by the use of paints, solvents or chemicals during product use are not covered by the warranty. This warranty will be void if the original identification label of the product has been altered or damaged. The integrity and completeness of the product and accompanying materials is not covered by the warranty, and you should inspect the product on-site upon receipt and dispute any discrepancies.

The above are all guarantees we make on our products. This warranty gives you specific legal rights, you may also have other rights under the law, and nothing in this document affects your consumer rights that you cannot exclude or limit under the law.

21. PRODUCT WARRANTY

Type	Warranty content
Controller	Controller assembly and central control panel
Lithium battery	Lithium battery and protect plate
Body	Frame assembly. Wheel hub motor. Front body. Brake assembly. Folding assembly. Body rod. Front fork. Front fork pole rotating parts. Control main wire.
spare part	Charger, thumb electric brake, thumb accelerator

Note: Consumables such as tire casing, headlight assembly, instrument cover, handle cover, fender, rear tail light, decorative cover, foot stand, charging port seat, rubber plug and on-board tool kit are not covered by the warranty policy.

22.WARRANTY CARD

When purchasing products, please fill in the following information completely and clearly, and affix the seal of the seller to protect your legal rights.

User information	Name	E-mail	
	Address		
	TEL	Zip code	
Product information	Product name	sale date	
	Product model	Invoice NO	
distributor information	Name	TEL	
	Address	Zip code	
Note: (1) This form should be confirmed by the seller's seal. (2) For products that are applicable to the relevant "Three Guarantees" regulations, this guarantee card is equivalent to the "Three Guarantees Certificate", (3) The maintenance record is subject to the maintenance certificate of the authorized service organization. After applying for the service, please keep it properly.			